



TECHNICAL INFORMATION

Slydring® Wear Rings | HiMod® Slydring® for Piston

Description

HiMod® Slydring® Wear Rings are made in special, modified thermoplastic material and can be used in both piston and rod areas of hydraulic cylinders for medium to high loads. HiMod® HM061 is a special glass fibre reinforced

polyacetal and is generally utilized in a wide range of hydraulic equipment such as: standard hydraulic cylinders (medium range), truck trail lift, telescopic cylinders, truck cranes, agriculture equipment and construction machinery.

Advantages

- Favorable price/performance ratio
- High compressive strength
- Easy installation on pistons and glands (gland bore > 40 mm)
- High wear resistance
- Water absorption 0.2 %
- High stiffness



Technical Data

Velocity, reciprocating	:	Max. 0.8 m/s
Temperature	:	-40 °C to +110 °C
Radial Slydring® Side Load Pressure	:	Max. 40 N/mm ² at 25 °C Max. 25 N/mm ² > 60 °C

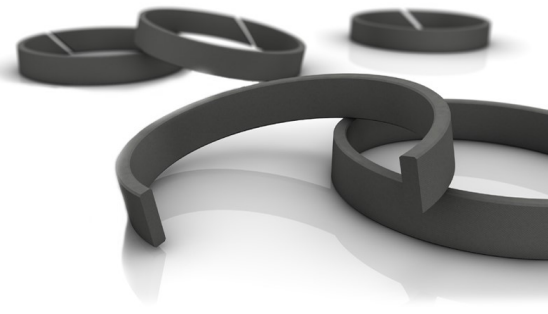

TECHNICAL INFORMATION

Slydring® Wear Rings | HiMod® Slydring® for Piston

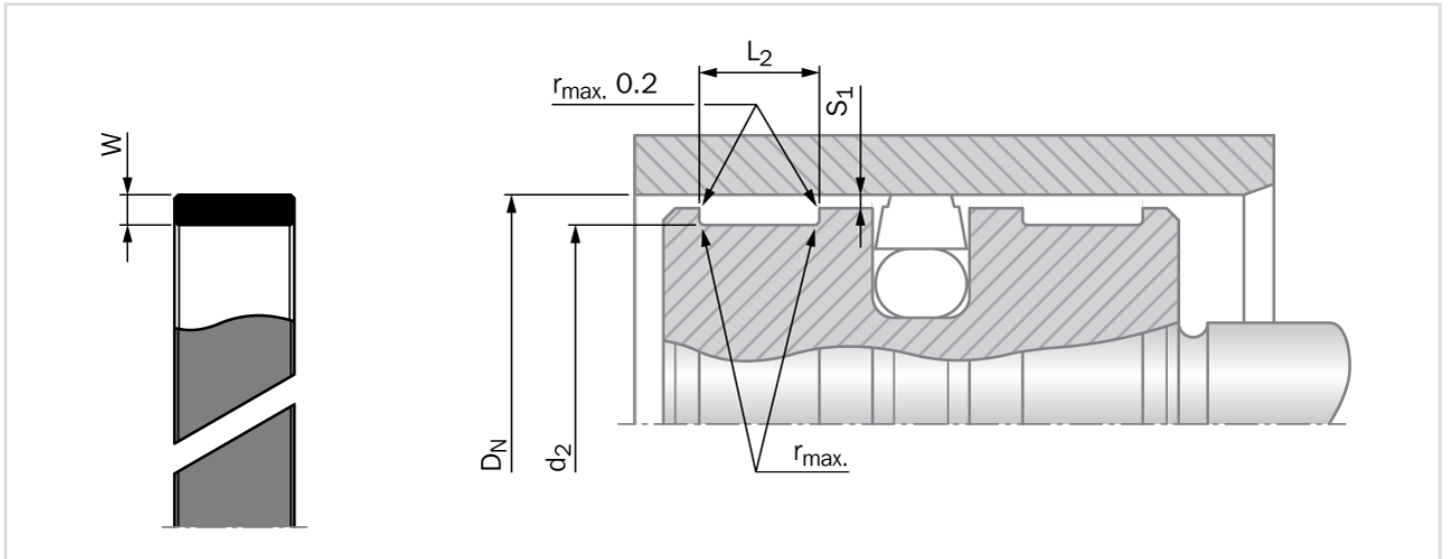

Recommended Radii for Groove Diameter

D_N	r max.
8 - 250	0.2
> 250	0.4

Drawing of part represents cut for ISO grooves. Non-iso grooves may use a straight cut depending on part number.

Radial Clearance S_1 *

Bore Diameter D_N	S_1 min.	S_1 max.
8 - 20	0.20	0.30
20 - 100	0.25	0.40
101 - 250	0.30	0.60
251 - 300	0.40	0.80

* Specifications valid only in the area of the Slydring®, but not for the seal area.

Important Note

Installation suggestions, material recommendations, parameters and further data provided are always subject to the particular field of use and the application in which the seal is intended to be used, in particular the interaction of the seal with other components of the application. Therefore they neither constitute an agreement on the legal and factual nature nor a guarantee of quality. Technical changes and errors remain reserved.